

NEW NORM

POST COVID SOLUTIONS

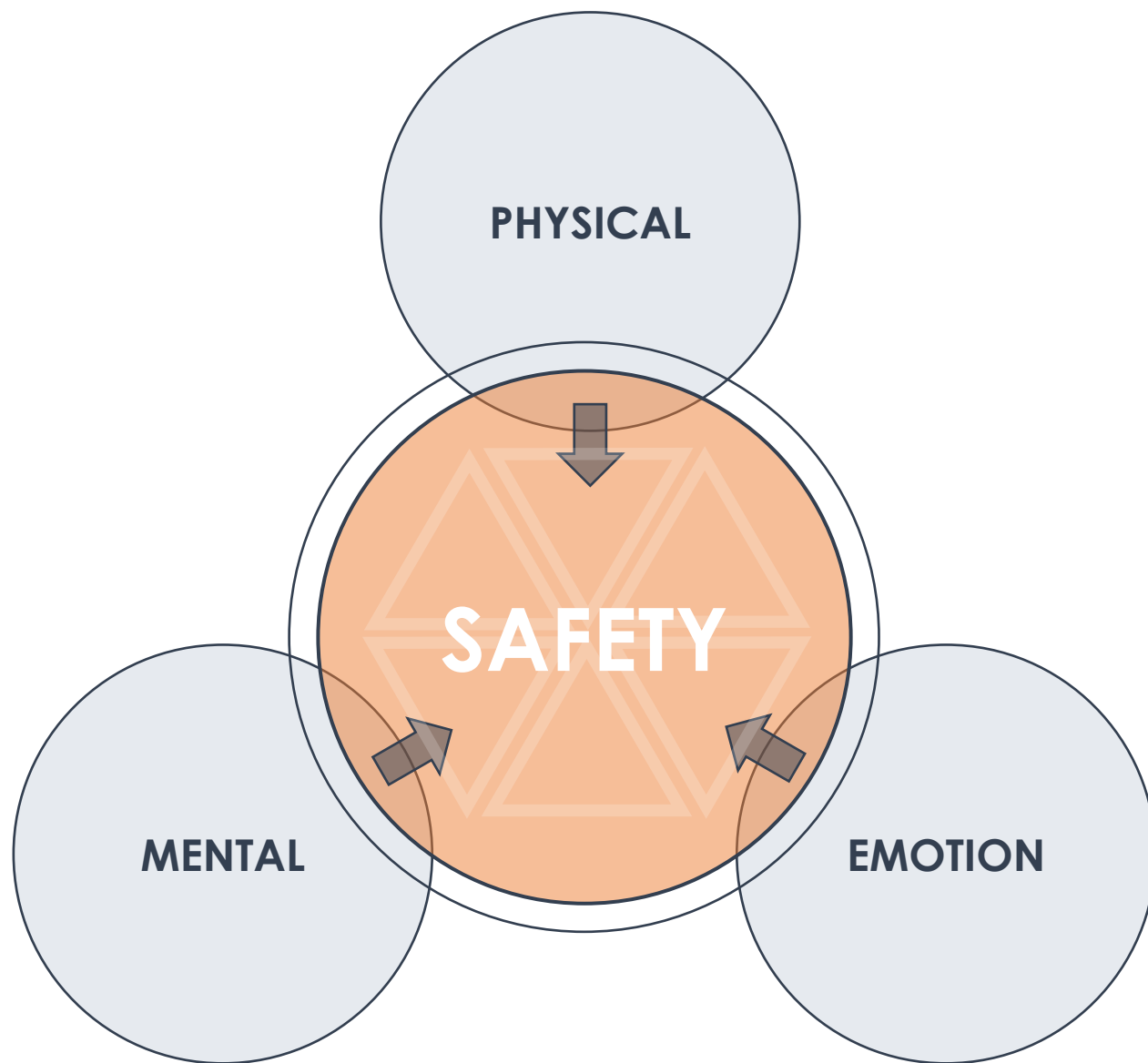

The logo for 'ekous' features a stylized green leaf icon to the left of the word 'ekous' in a lowercase, sans-serif font. A registered trademark symbol (®) is located at the top right of the word.



PSYCHOLOGICAL PREPARATION

PHYSICAL

Ability to stay **healthy** and minimize exposure to infectious virus

MENTAL

Health factors to ensure more **focus**
And **productive** mindset

EMOTION

Working **environment** with appropriate
preventive measures



SOCIAL DISTANCING PRACTICES

ADAPTATION

Our past social life or working environment are no longer valid to present. Anxiety and stress level eventually building up at our workplace. This experiences have impact our **Physical – Mental – Emotion** tremendously. Safety precaution is the main priority with as such SOPs to abide within our working environment. Thus, EKOUS has committed to provide various of solutions in order to accommodate into existing workplace.

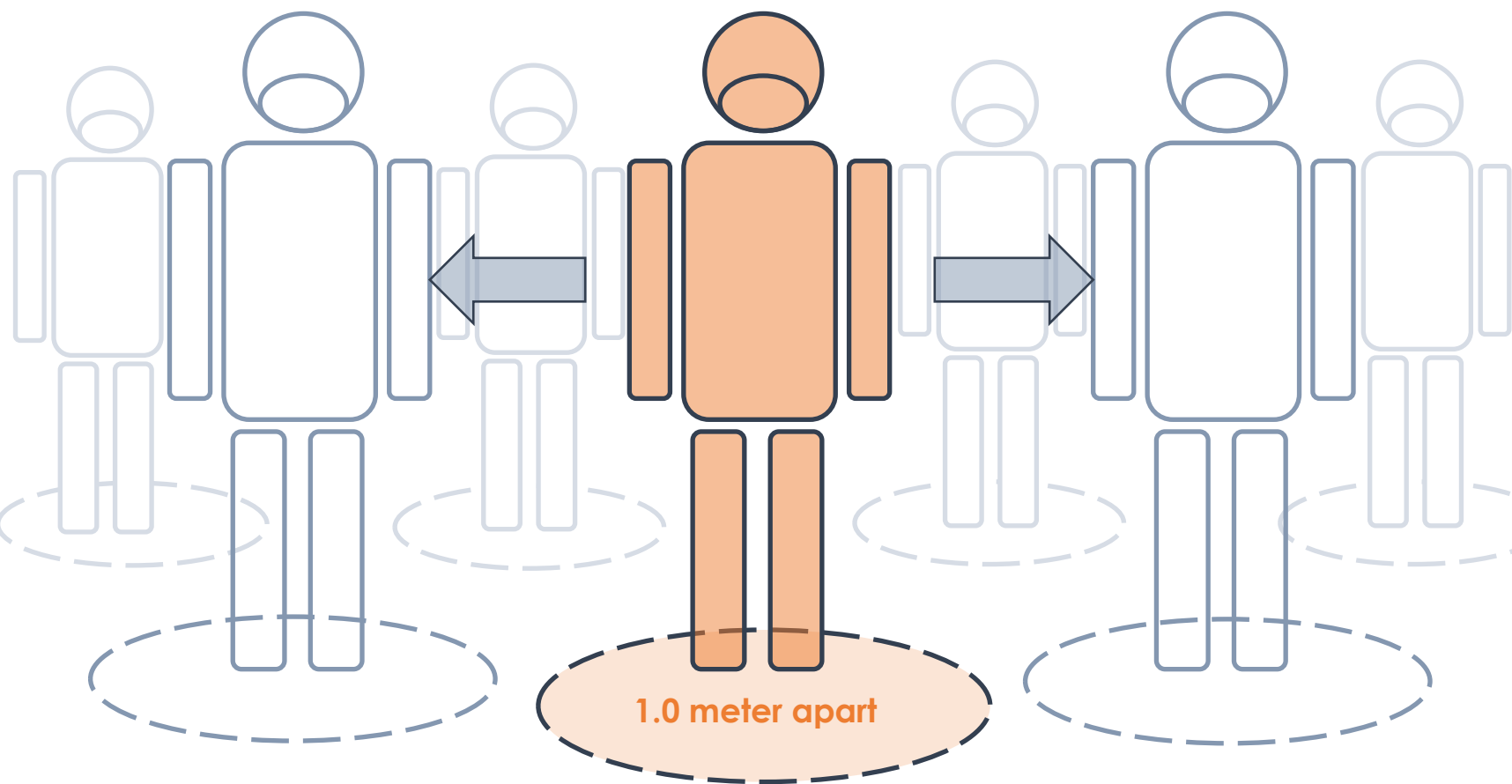



WORKPLACE ENHANCEMENT

1. Workstation

Pending on various existing configurations, EKOUS solutions can be **easily allocate** without any hassle.

2. Executive station

Open space can be separated by applying mobile screen to **define**.

3. Meeting area

High density space can be quadrant off With portable screen with added **acoustic values**.

4. Pantry / Discussion area

Addon portable screen to segregate for staff **safety interaction**.

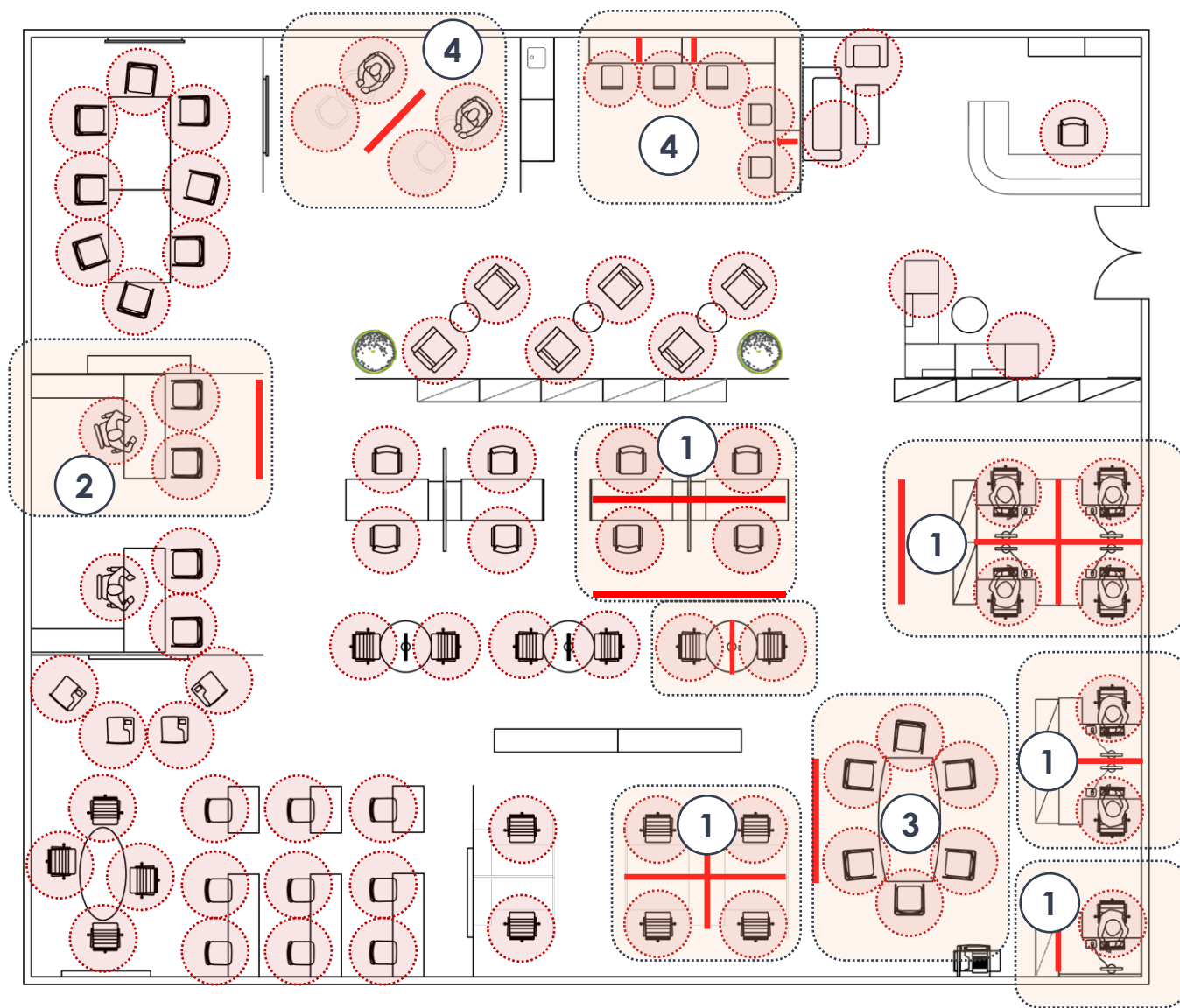

*EKOUS solutions



DESIGN DEVELOPMENT PHASE - 1

Module A
Portable screen

Module C
Isolation screen

Module B
Divider screen

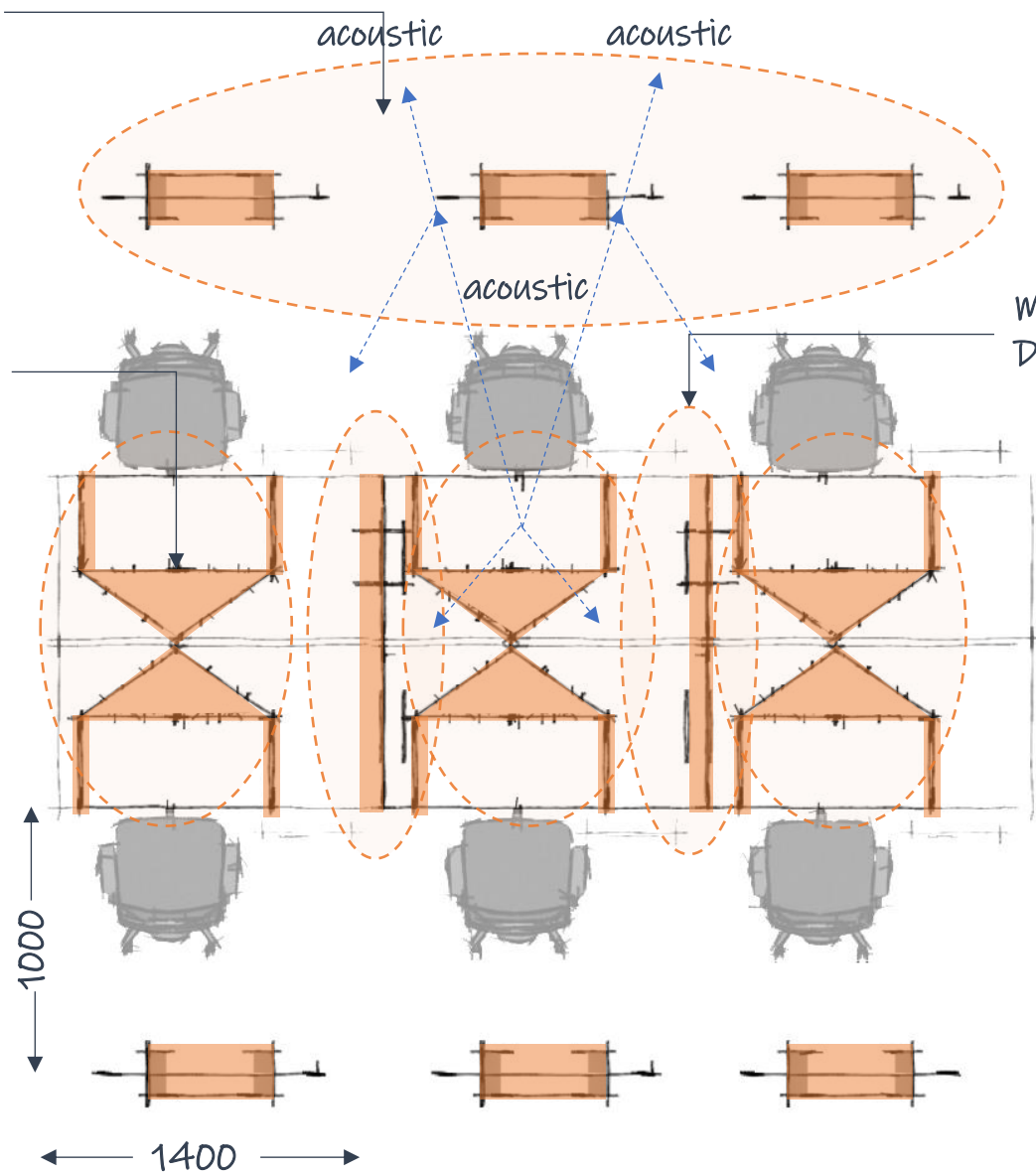

Module A – Portable screen

Open space **segregation**

Module B – Divider screen

Work space **definition**

Module C – Isolation screen

Individual zone **compartment**



DESIGN DEVELOPMENT PHASE - 2

Module A – Portable screen Open space **segregation**

Light weight portable screen with acoustic properties where catered for various of open space. It is detachable Where provide flexibility and effectively Subdue unnecessary drifting noises.

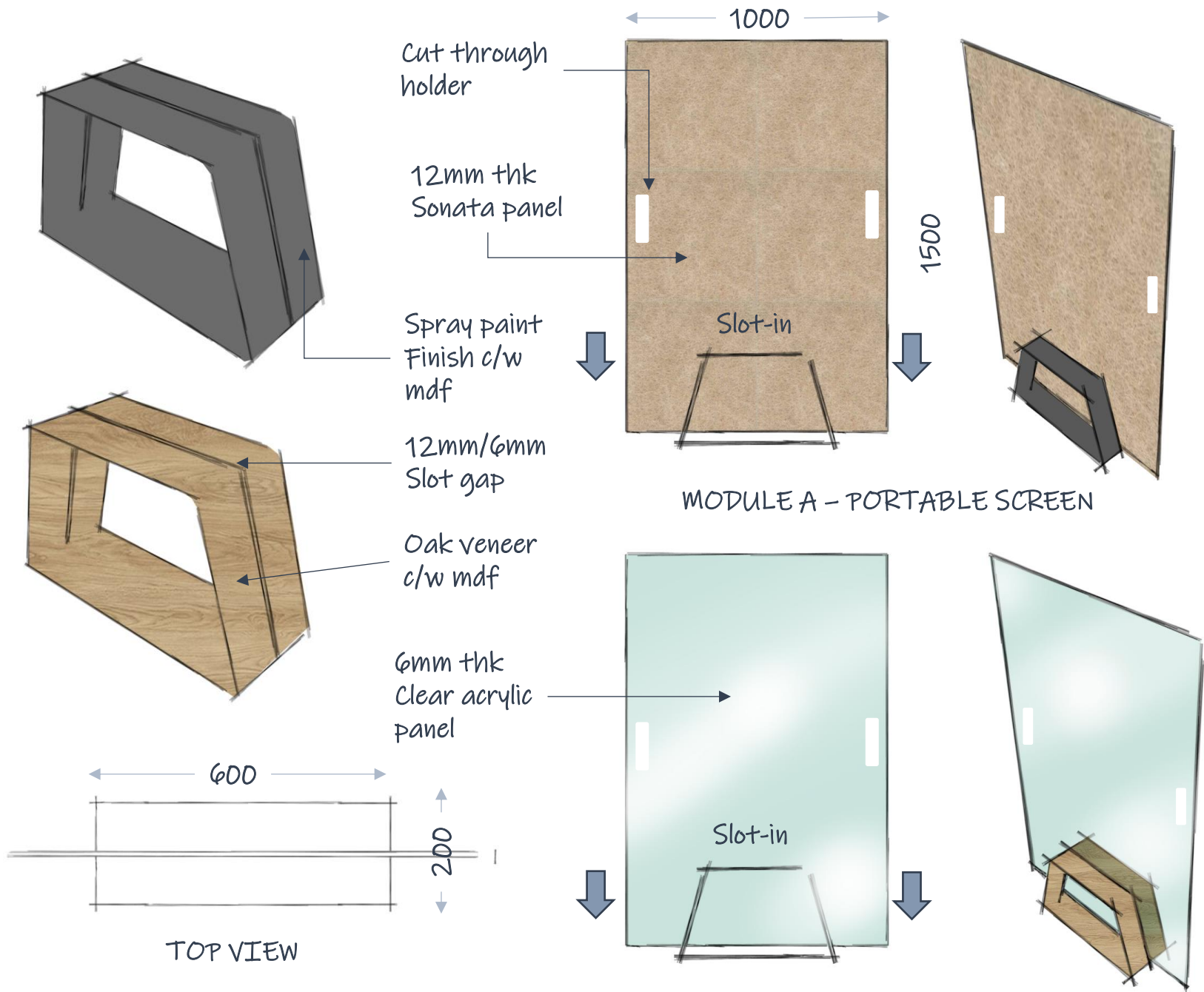



DESIGN DEVELOPMENT PHASE – 3

Module B – Divider screen Work space **definition**

Define space in between areas with simple assemble. Versatile and flexible to suit any desire and concept in any existing working environment.

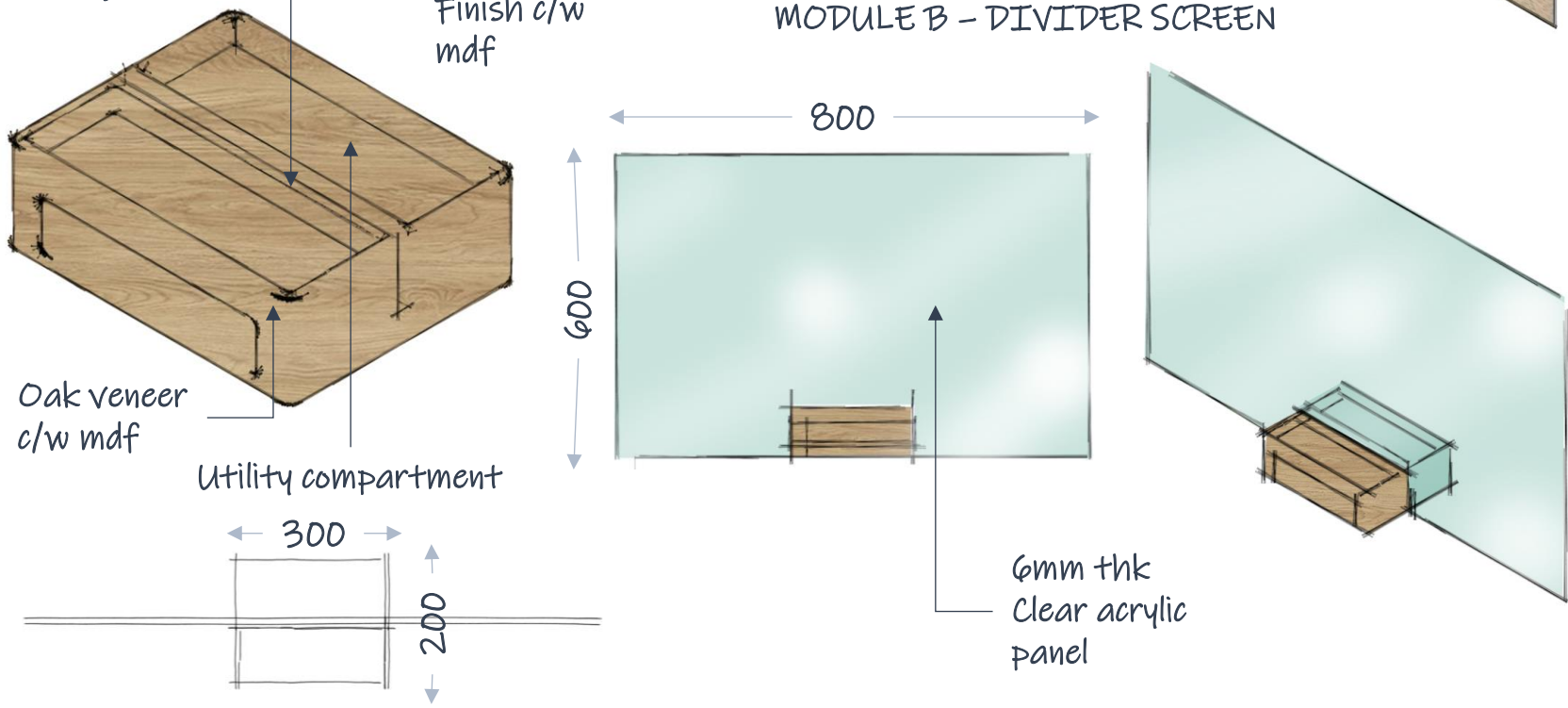
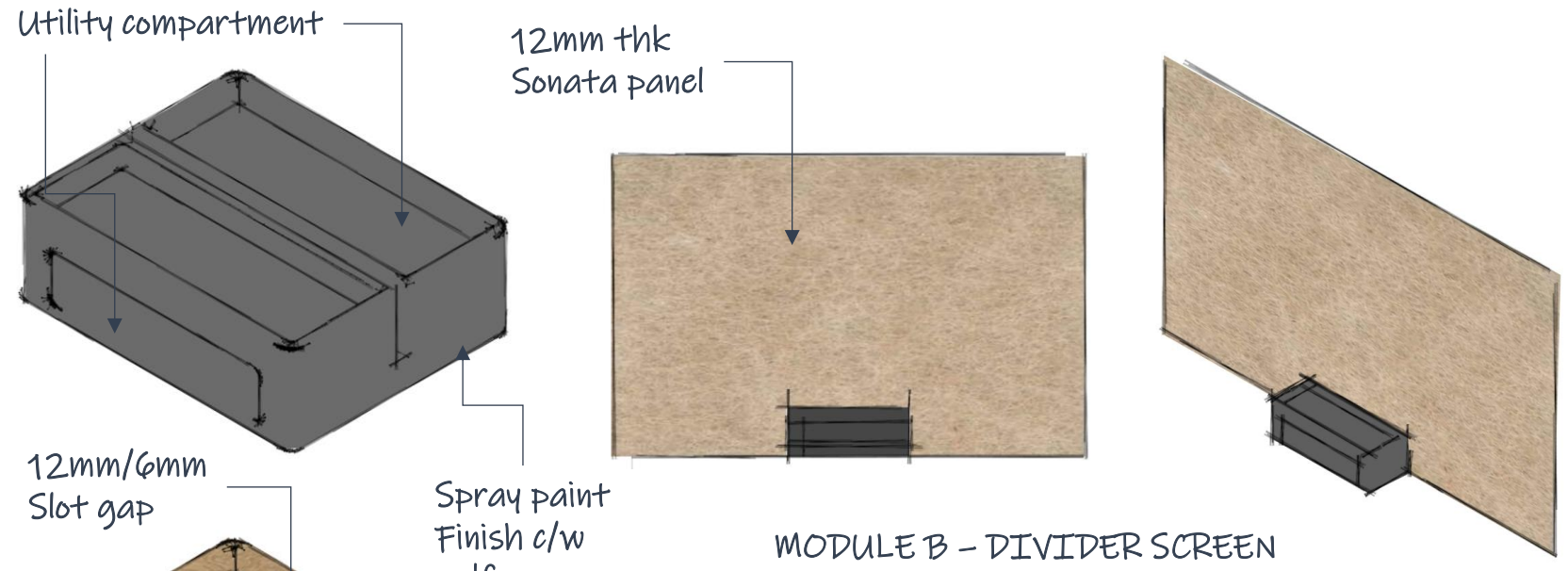



DESIGN DEVELOPMENT PHASE – 4

Module C – Isolation screen c/w canopy Individual zone **compartment**

Mobility trend are going to depicts newer generation. Thus, it has been innovated which is a flexible mobilization for user to apply any forms of space.

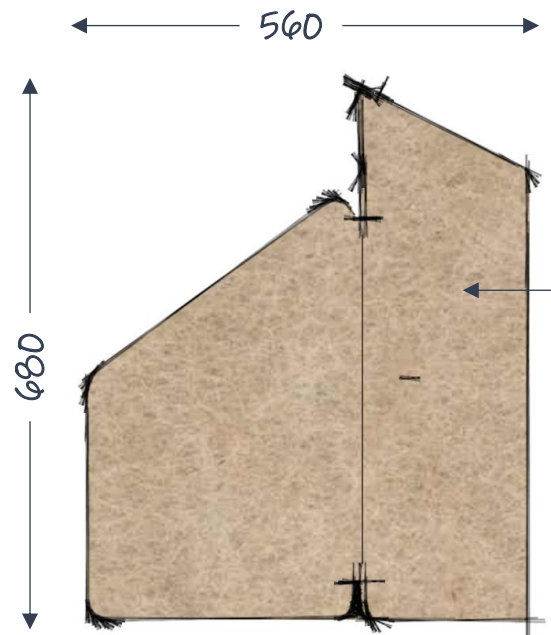

9mm thk
Sonata panel

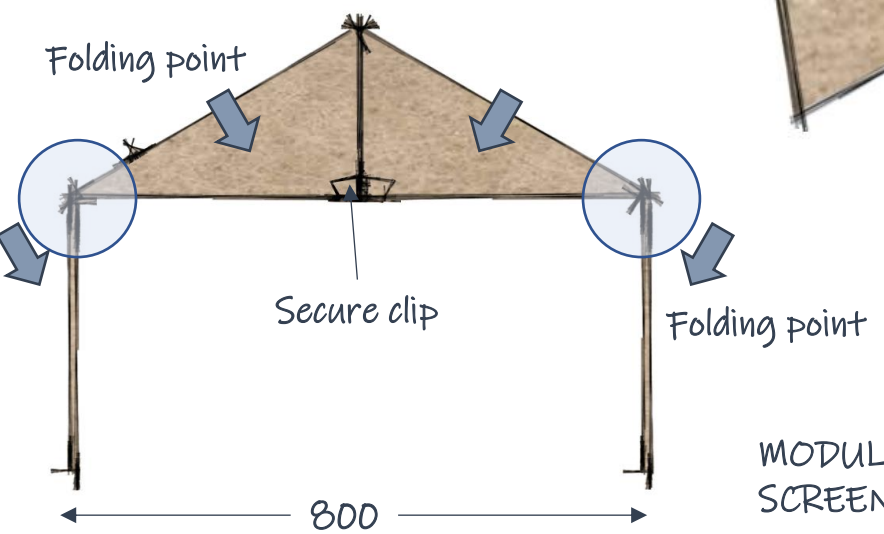
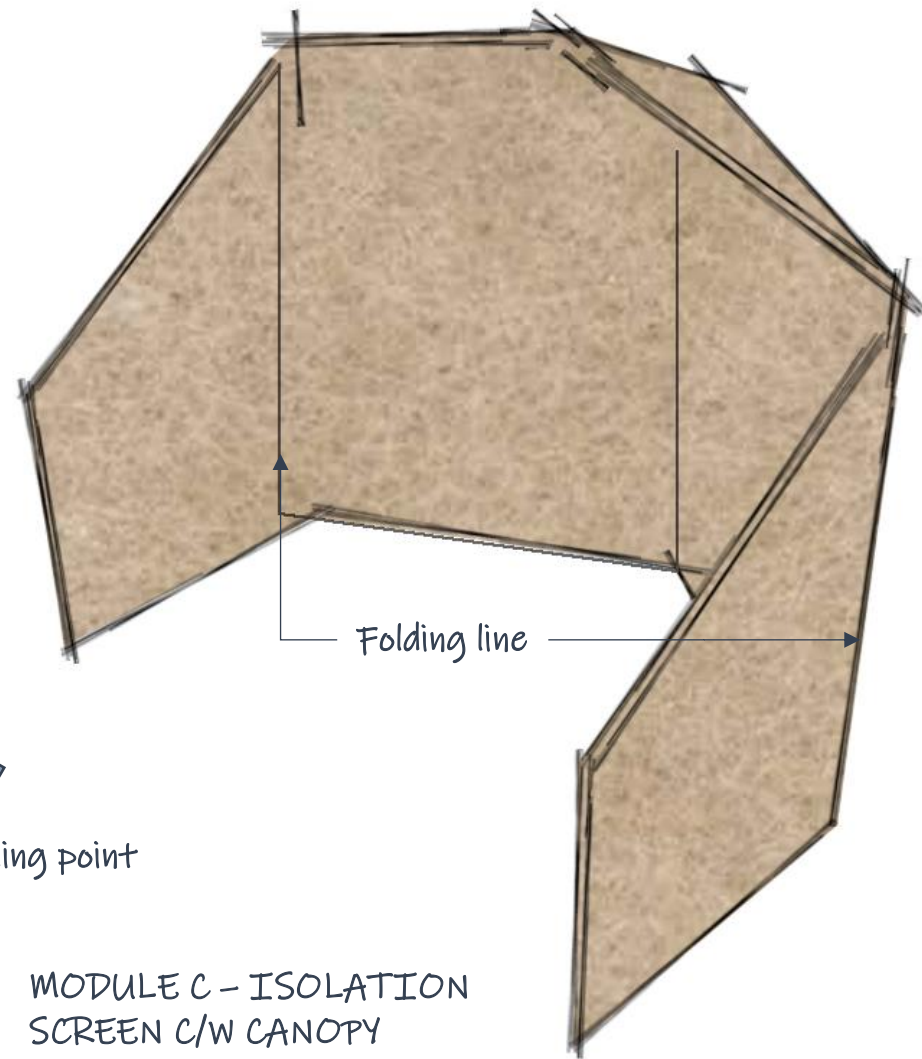

MODULE C – ISOLATION
SCREEN C/W CANOPY



DESIGN DEVELOPMENT PHASE – 5

Module C – Isolation screen without canopy Individual zone **compartment**

Mobility trends are going to depict a new generation. Thus, it has been innovated which is a flexible mobilization for user to apply any forms of space.

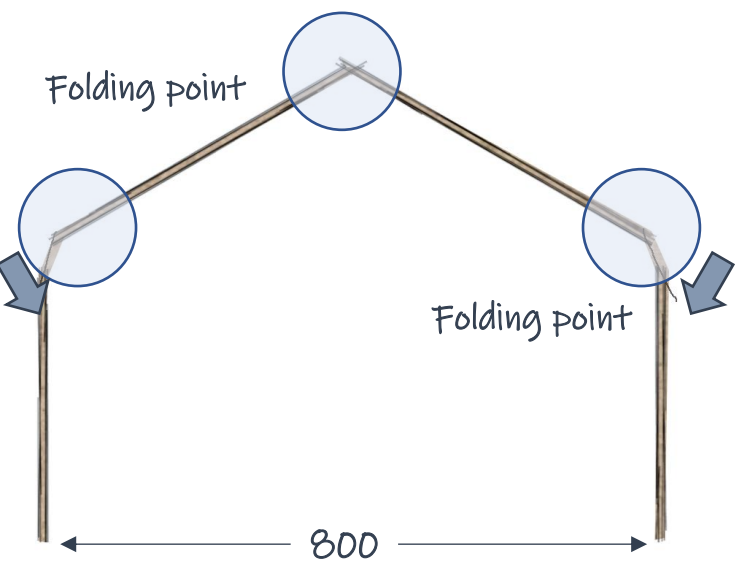
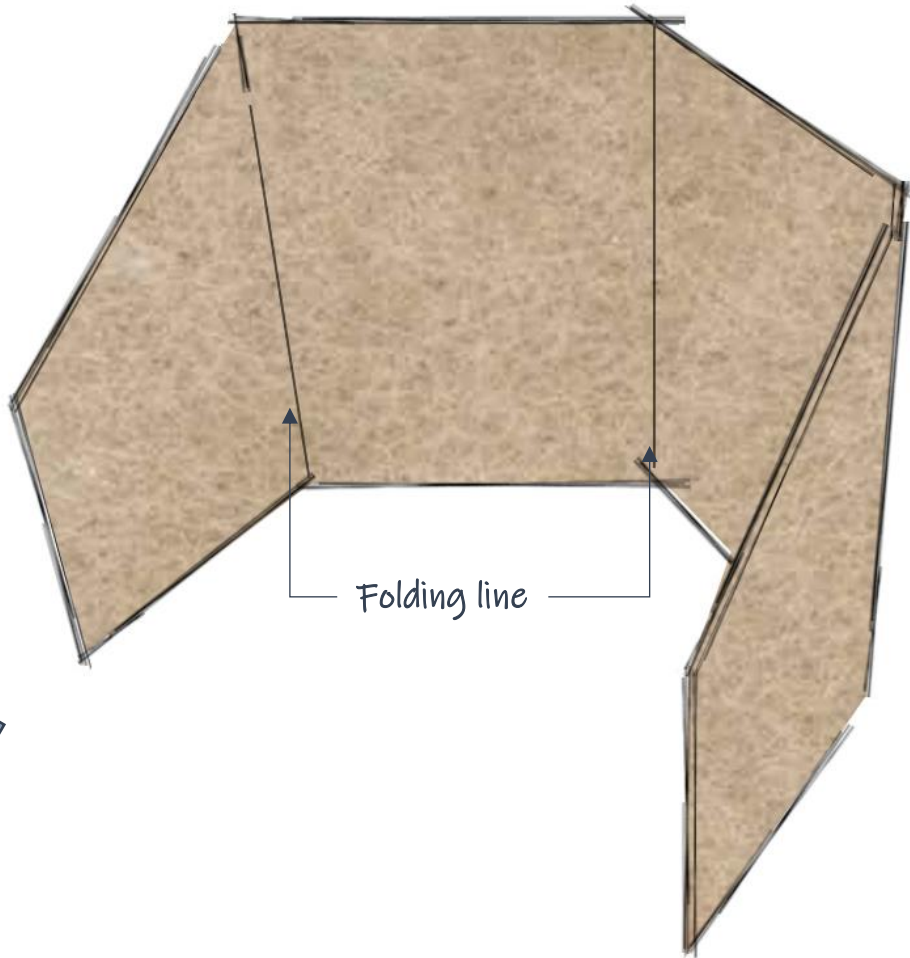
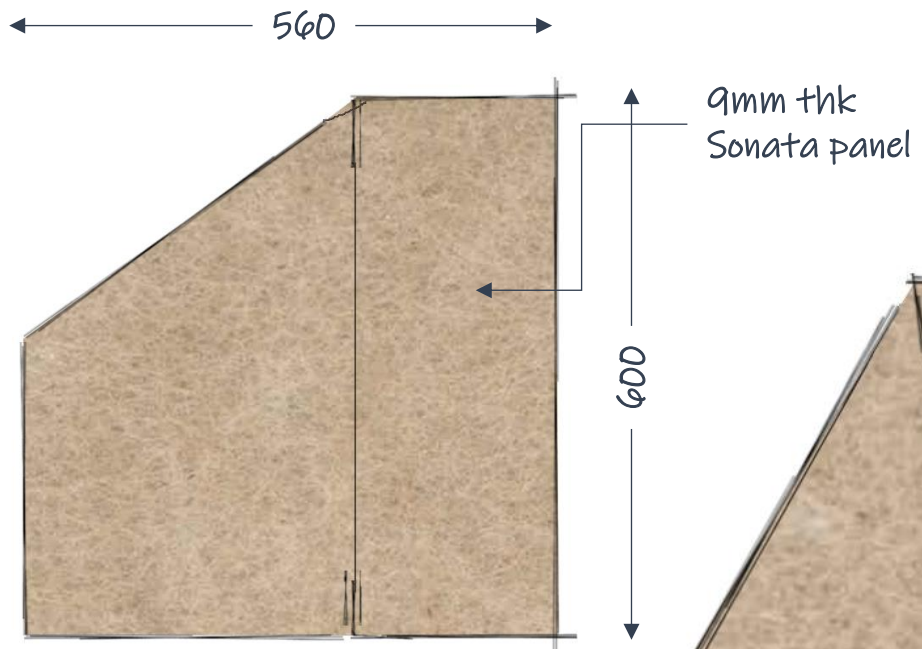



MODULES COMBINATION

Module A – Portable screen

Open space segregation

Module B – Divider screen

Work space definition

Module C – Isolation screen

Individual zone compartment

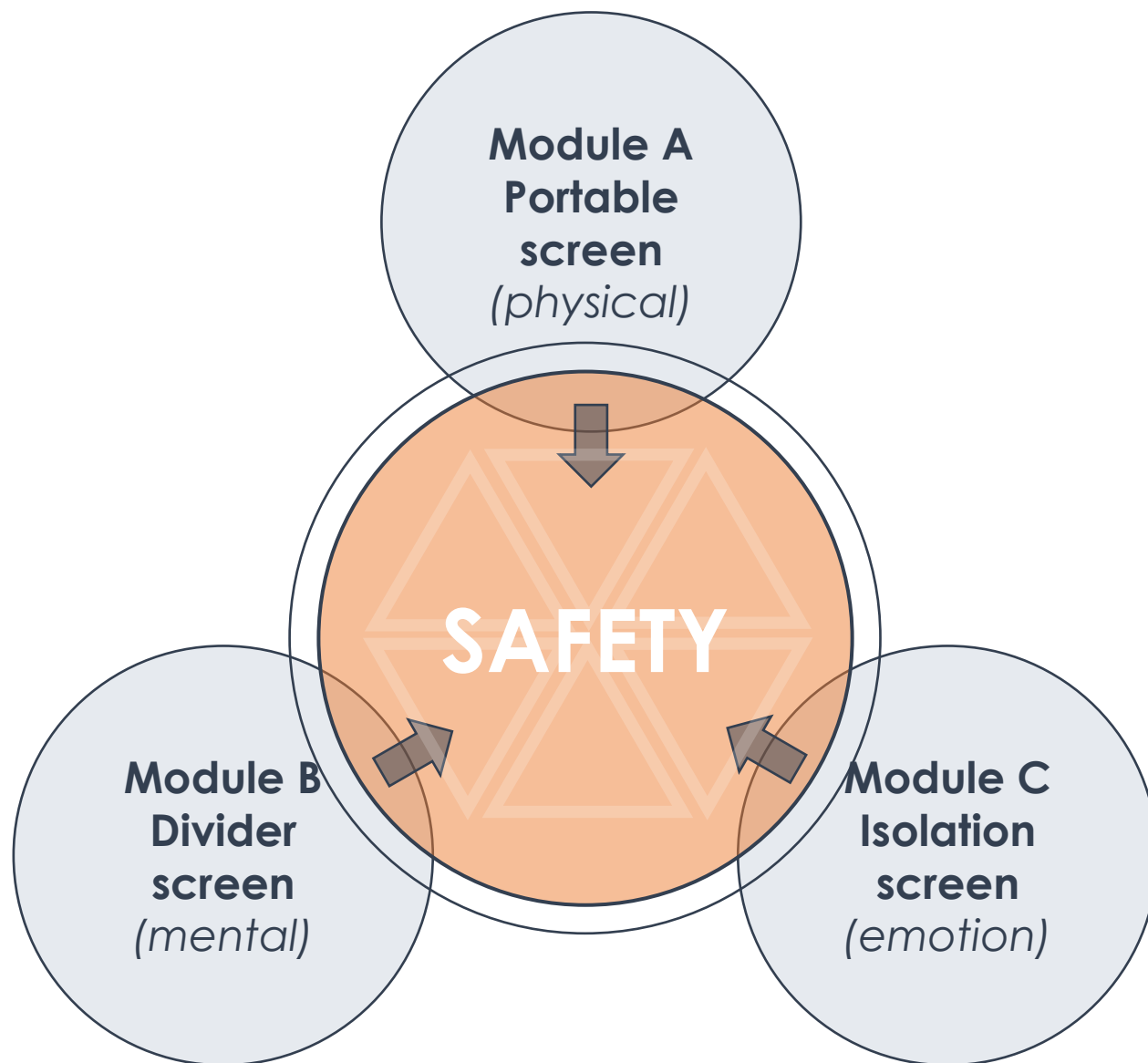



CONFIGURATION 1

BEFORE



AFTER



HOTDESKING

MODULE-A
PORTABLE SCREEN

MODULE-B
DIVIDER SCREEN

MODULE-C
ISOLATION SCREEN

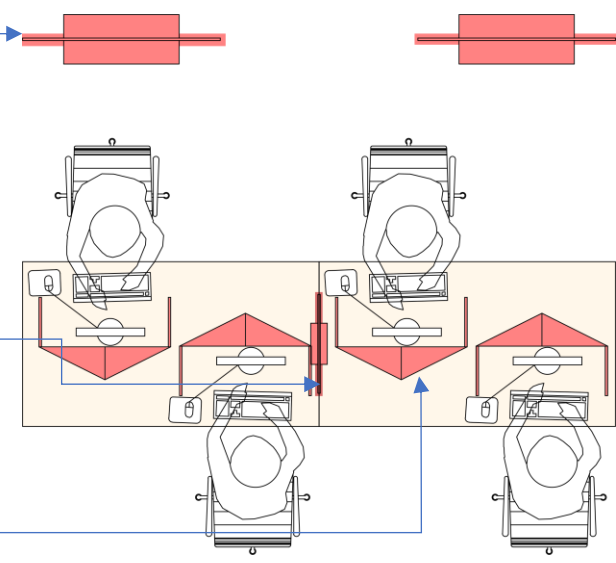



CONFIGURATION 2

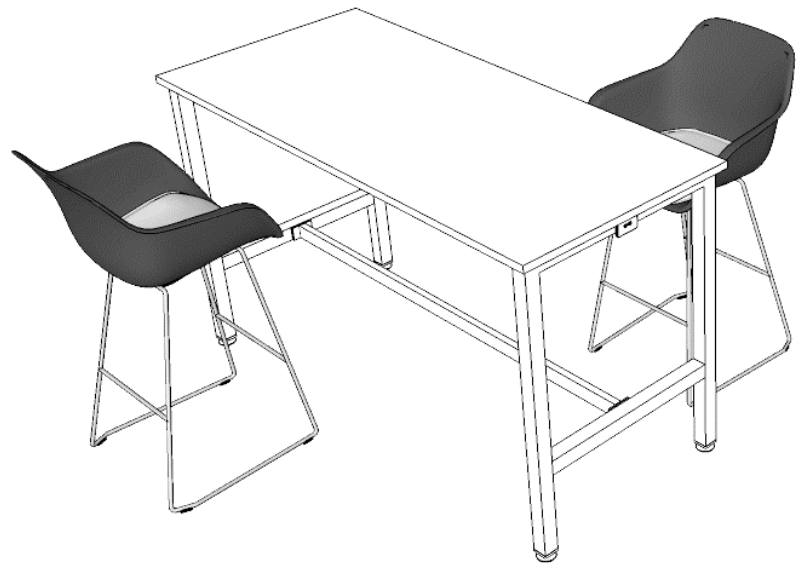

BEFORE

HIGH TABLE

AFTER

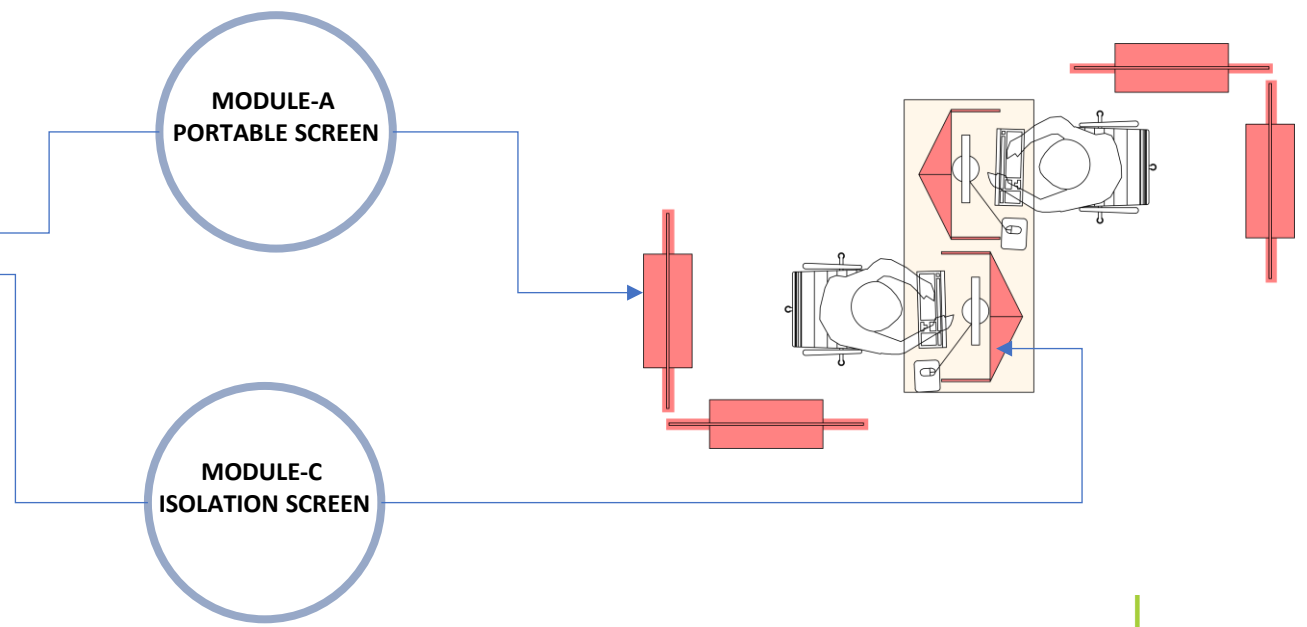
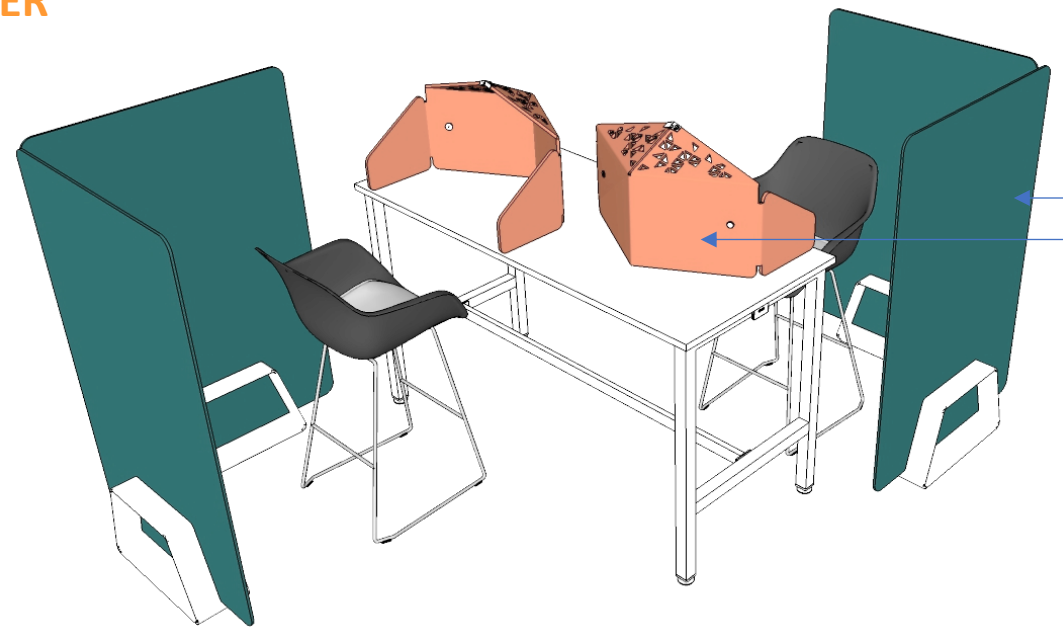



CONFIGURATION 3



BEFORE

WORKSTATION



AFTER

MODULE-A
PORTABLE SCREEN

MODULE-B
DIVIDER SCREEN

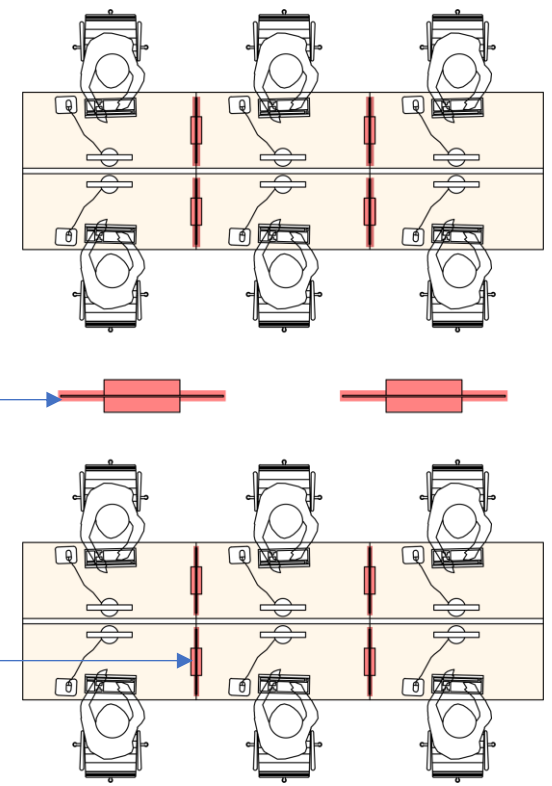



CONFIGURATION 4

BEFORE

EXECUTIVE WORKSTATION

AFTER



MODULE-A
PORTABLE SCREEN

MODULE-B
DIVIDER SCREEN

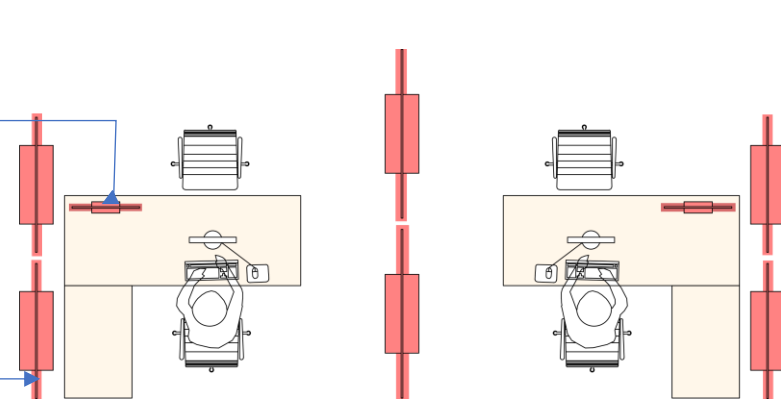



CONFIGURATION 5



BEFORE

DISCUSSION AREA

AFTER

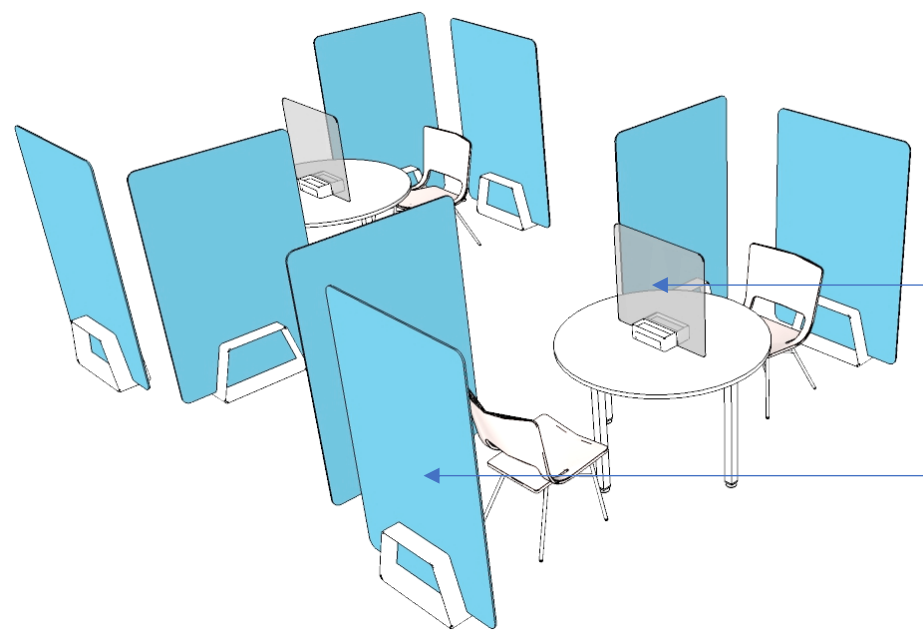

**MODULE-A
PORTABLE SCREEN**

**MODULE-B
DIVIDER SCREEN**

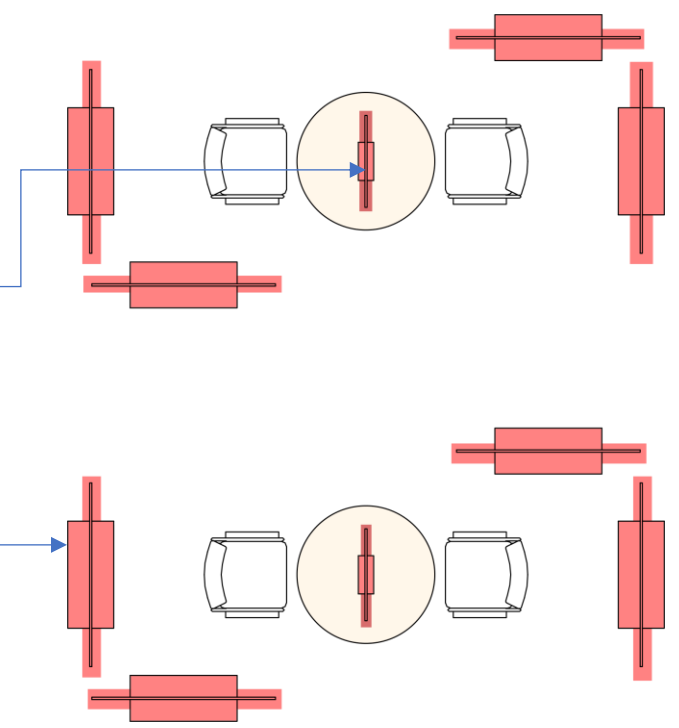



CONFIGURATION 6



BEFORE

MEETING AREA

AFTER



MODULE-B
DIVIDER SCREEN

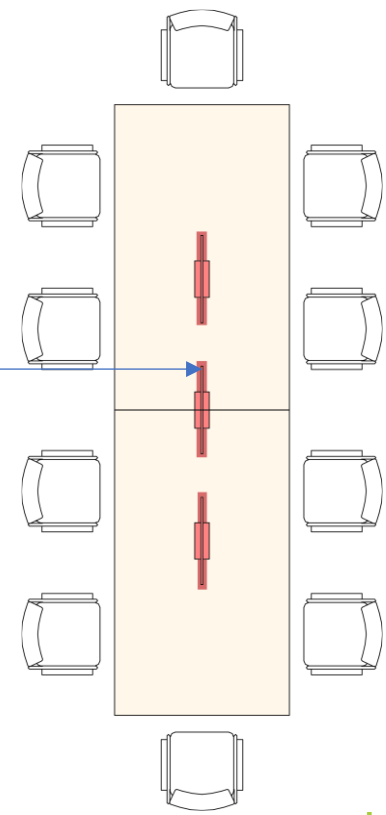



MODULE A – PORTABLE SCREEN

Open space **segregation**

Lightweight portable screen with acoustic properties where catered for various open space. It is detachable where provide flexibility and effectively subdue any unnecessary drifting noise.

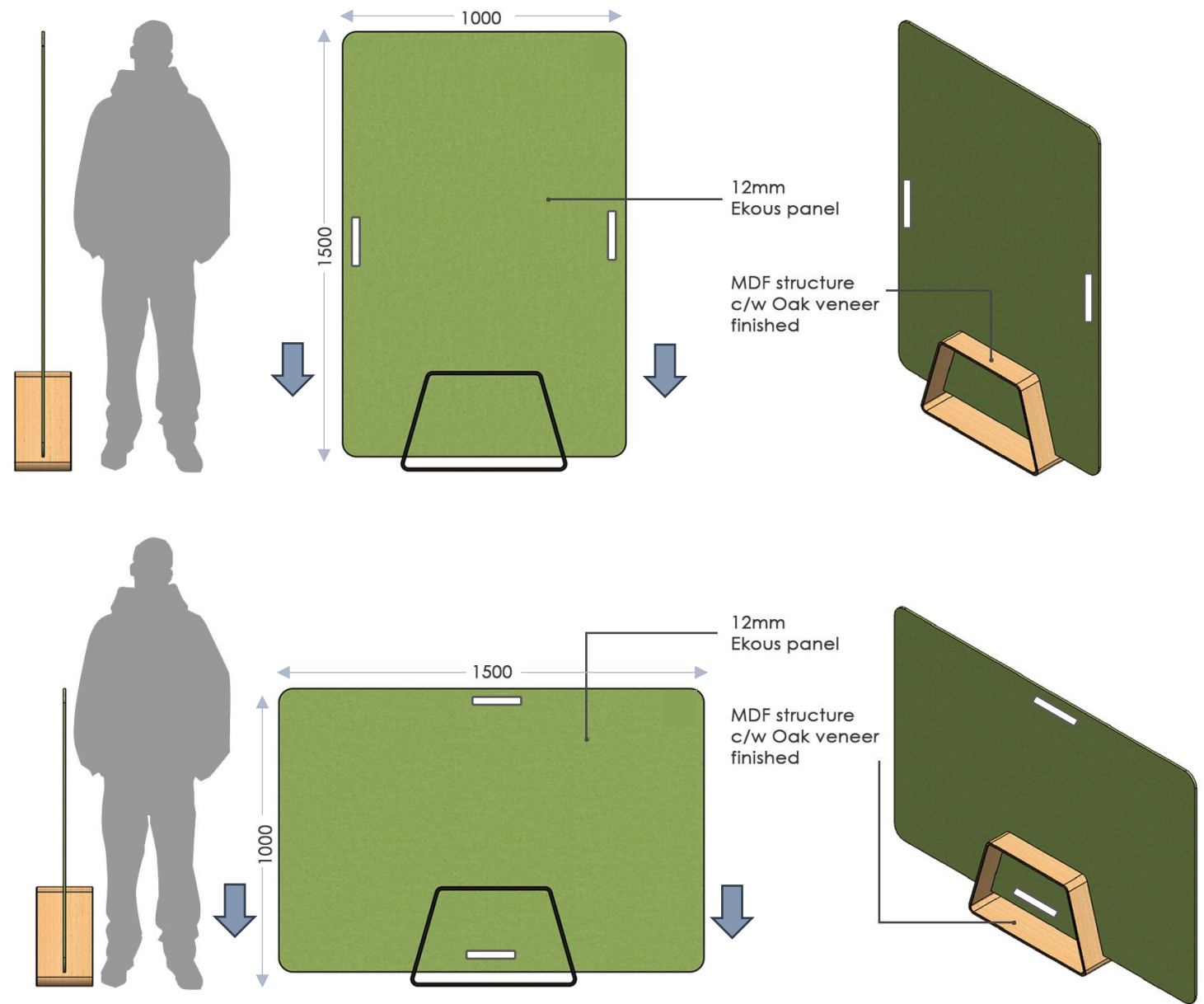



MODULE B – DIVIDER SCREEN

Work space **definition**

Define space in between areas with simple assemble. Versatile and flexible to suit any desire and concept in any existing working environment.

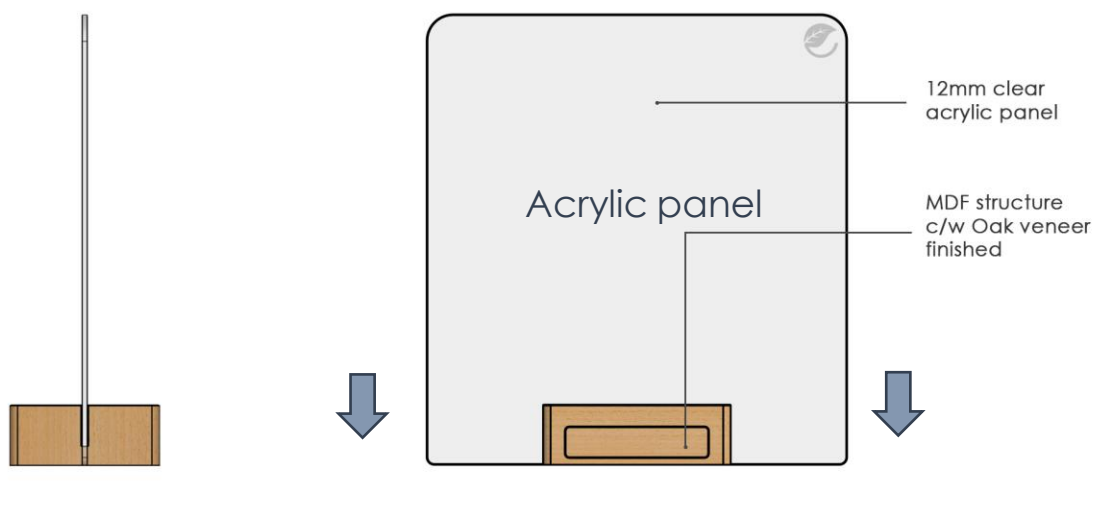
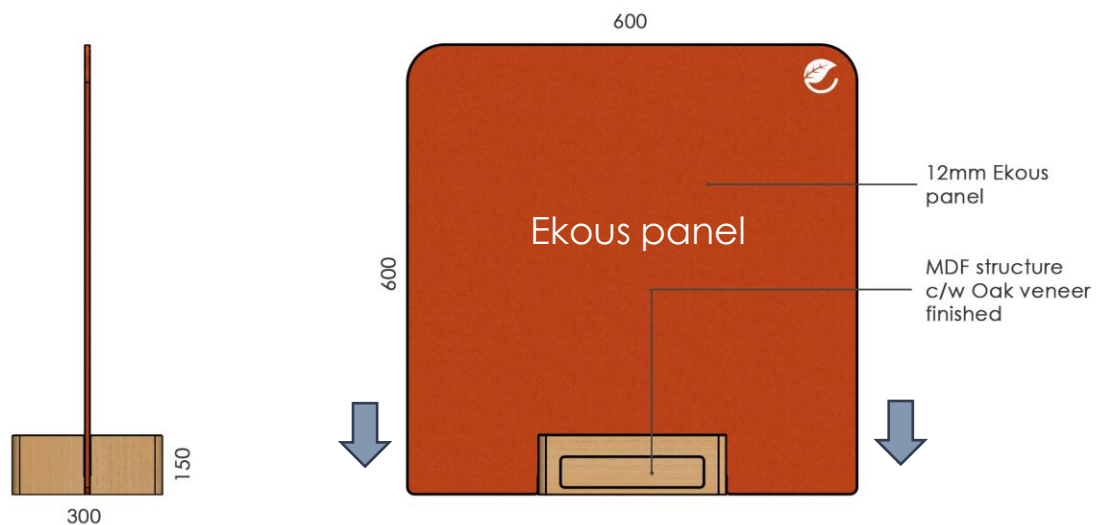

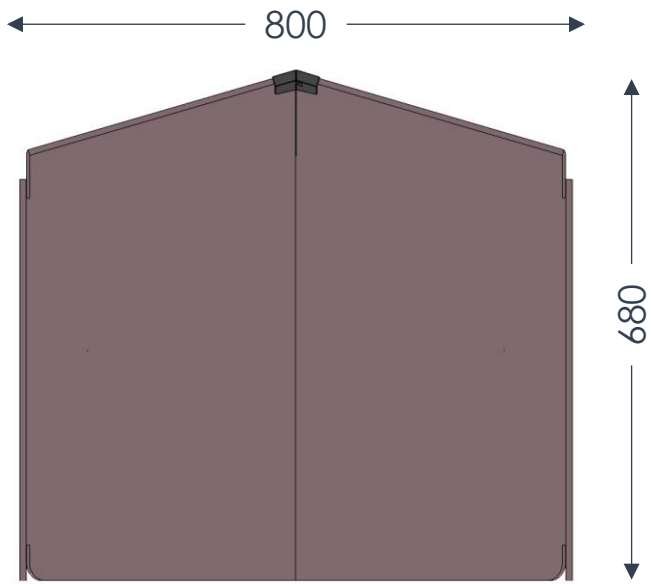

Front view – with canopy

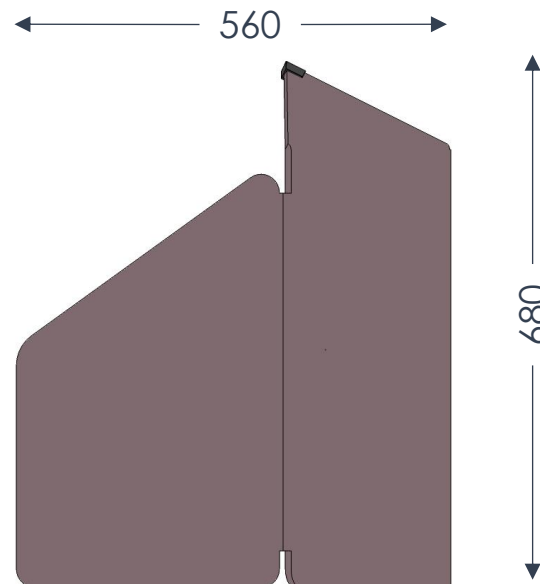

Side view – with canopy

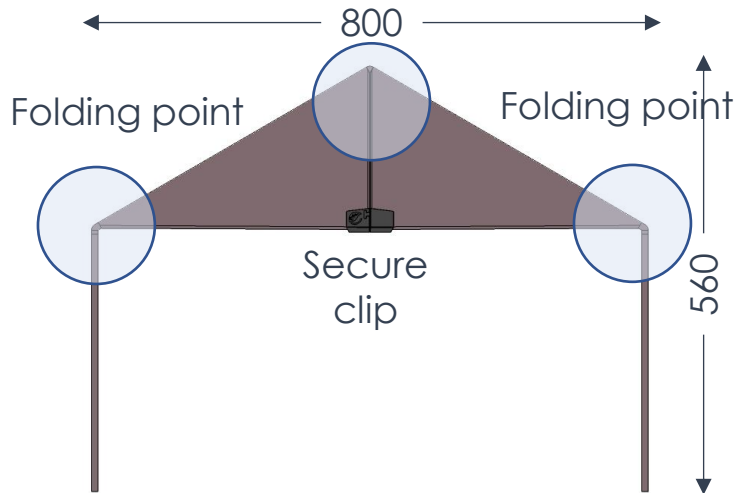

Top view – with canopy

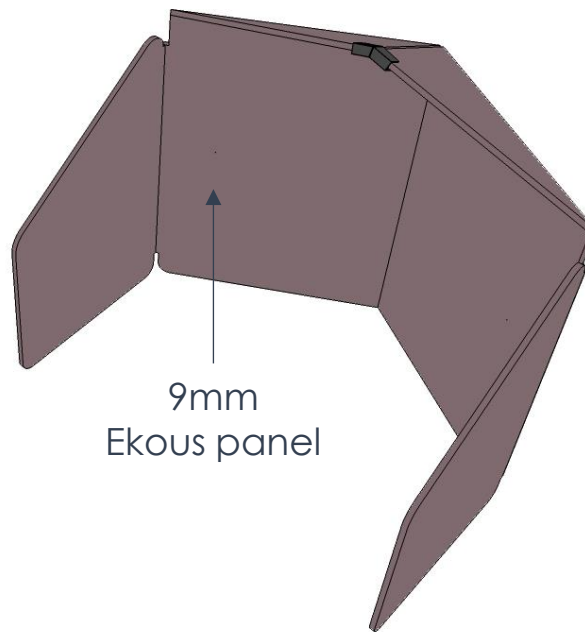

MODULE C – ISOLATION SCREEN

Individual zone **compartment**

Mobility trend are going to depicts newer generation. Thus, it has been innovated which is a flexible mobilization for user to apply any forms of space.

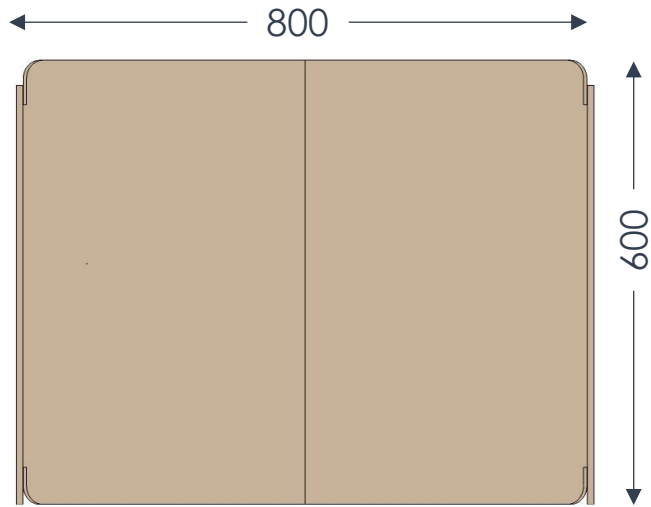

Front view – with canopy

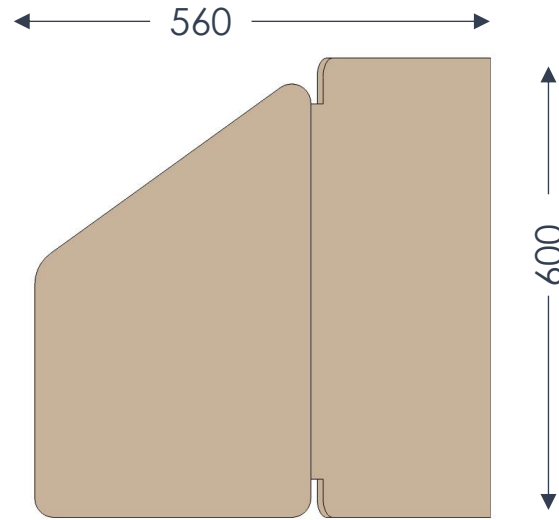

Side view – with canopy

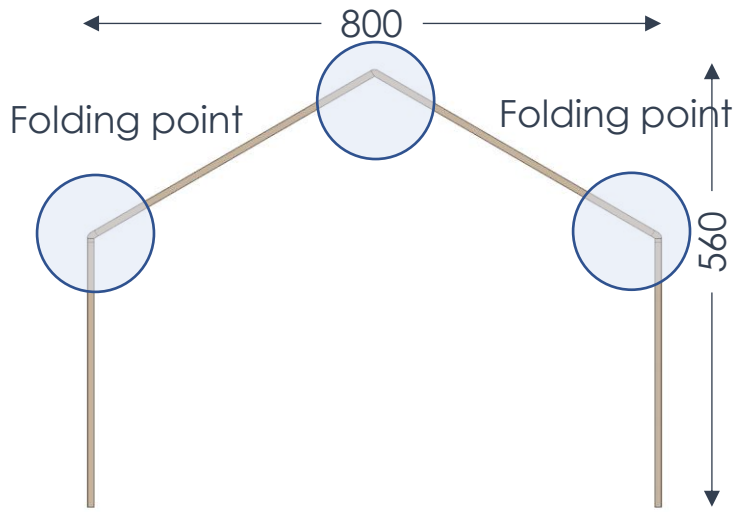

Top view – with canopy

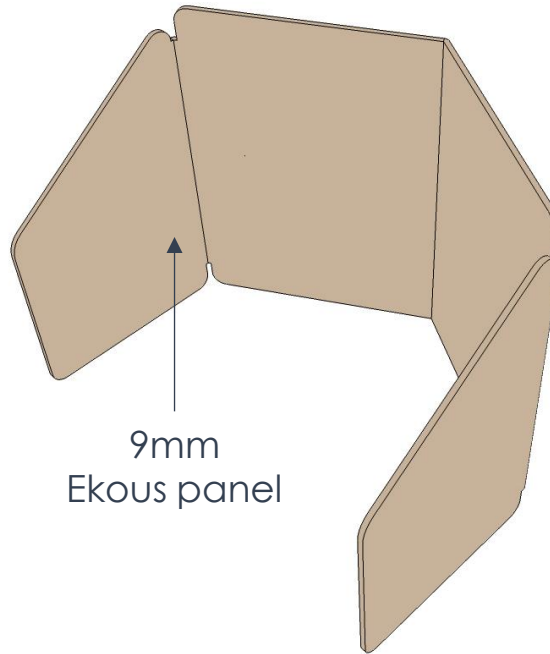

MODULE C – ISOLATION SCREEN

Individual zone **compartment**

Mobility trend are going to depicts newer generation. Thus, it has been innovated which is a flexible mobilization for user to apply any forms of space.

ASSEMBLY REFERENCE

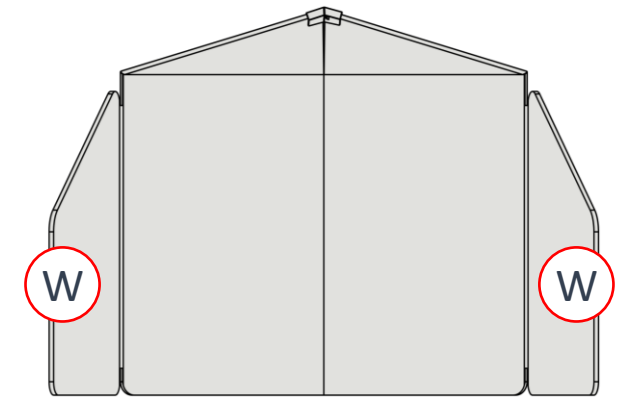
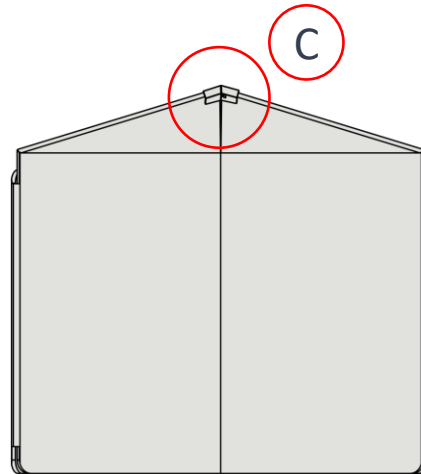
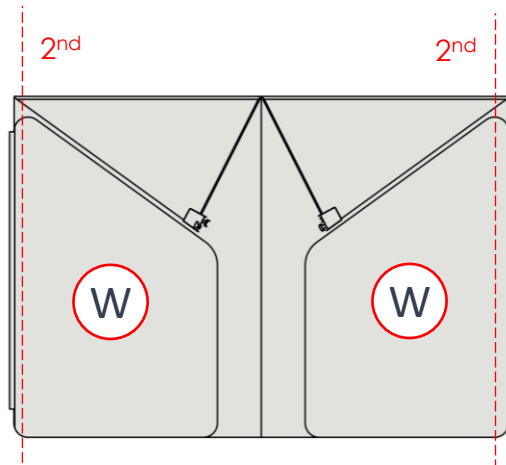
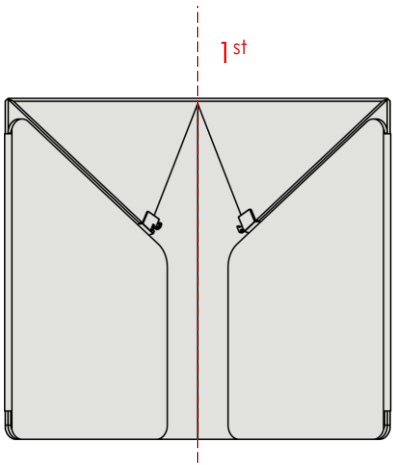
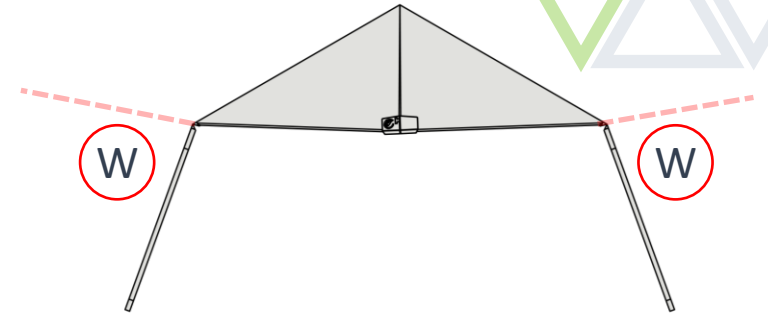
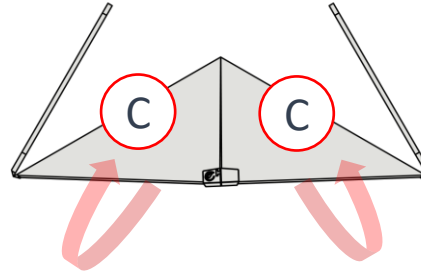
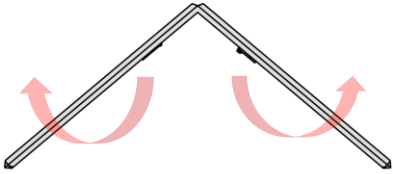

STEP 1
Flatten the 1st foldable groove

STEP 2
Flip-out on 2nd foldable groove to obtain both wings **W**

STEP 3
Clip-on of both CANOPY To secure **C**

STEP 4
Adjust both wings to suit



ACTUAL PRODUCT

Individual zone **compartment**

Mobility trend are going to depicts newer generation. Thus, it has been innovated which is a flexible mobilization for user to apply any forms of space.





ACTUAL PRODUCT

Individual zone **compartment**

Mobility trend are going to depicts newer generation. Thus, it has been innovated which is a flexible mobilization for user to apply any forms of space.

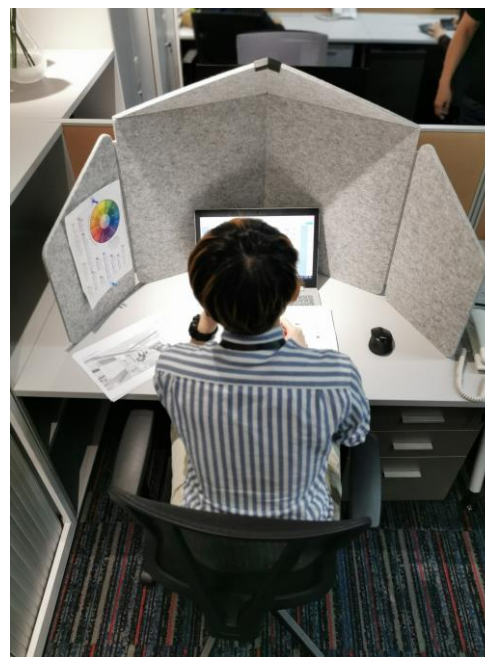

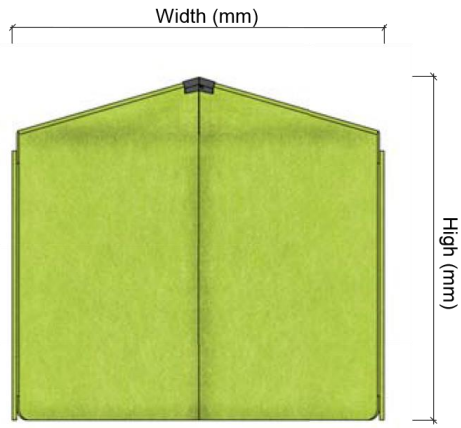

Front View
(EKOUS 9mm Thk)

Width : 800W (mm)
High : 680H (mm)

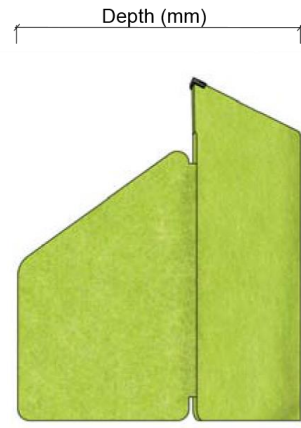

Side View
(EKOUS 9mm Thk)

Depth : 560W (mm)

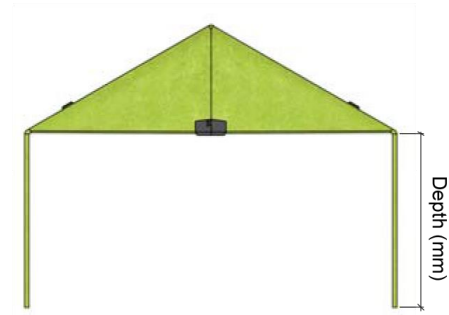

Top View
(EKOUS 9mm Thk)

Depth : 360W (mm)

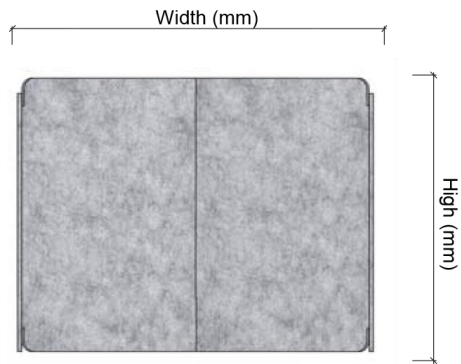

Front View
(EKOUS 9mm Thk)

Width : 800W (mm)
High : 600H (mm)

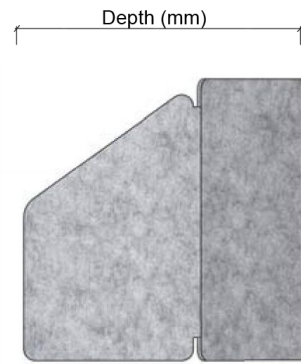

Side View
(EKOUS 9mm Thk)

Depth : 560W (mm)

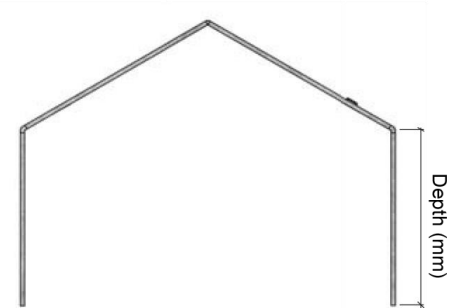

Top View
(EKOUS 9mm Thk)

Depth : 360W (mm)



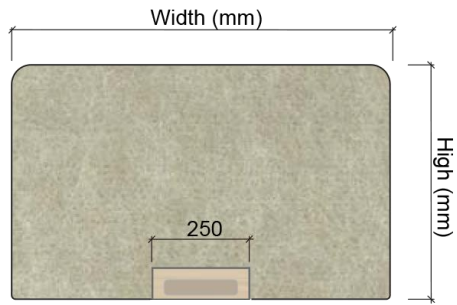

Front

Ekous (12mm thk)

Width : 600/750/800W (mm)
High : 600H (mm)

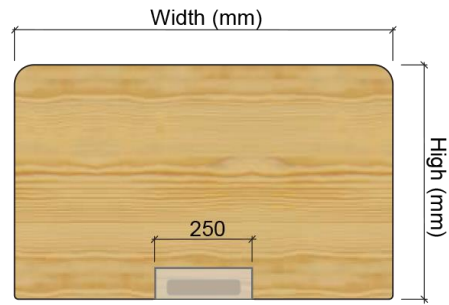

Front

MFC (12mm thk)

Width : 600/750/800W (mm)
High : 600H (mm)

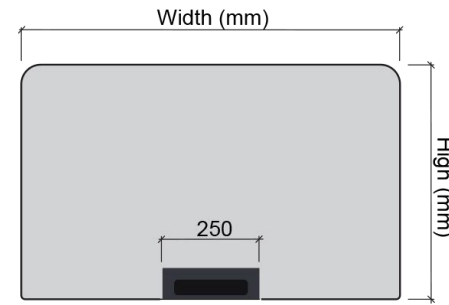

Front

Acrylic (6mm thk)

Width : 600/750/800W (mm)
High : 600H (mm)



Side

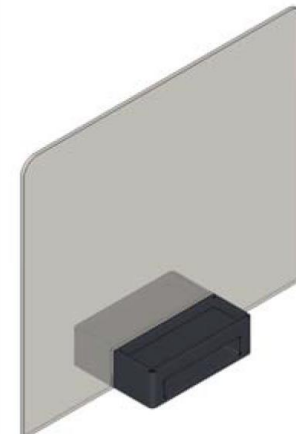

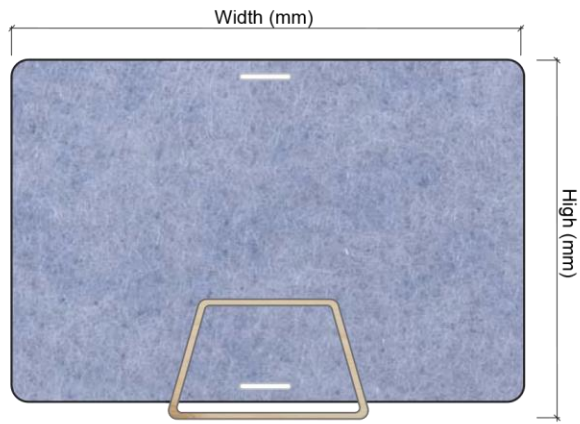

Front

Ekous (12mm thk)

Width : 1500W (mm)
High : 1000H (mm)

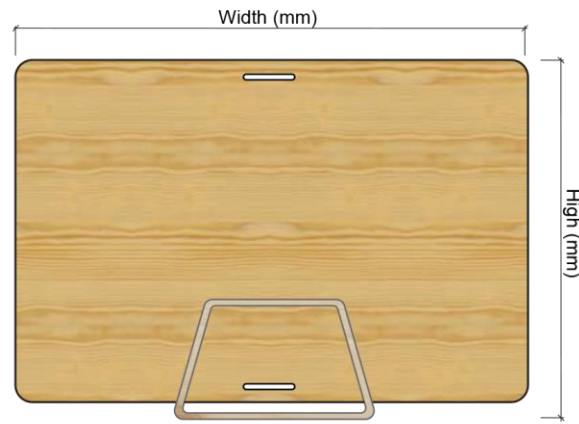

Front

MDF (12mm thk)

Width : 1500W (mm)
High : 1000H (mm)

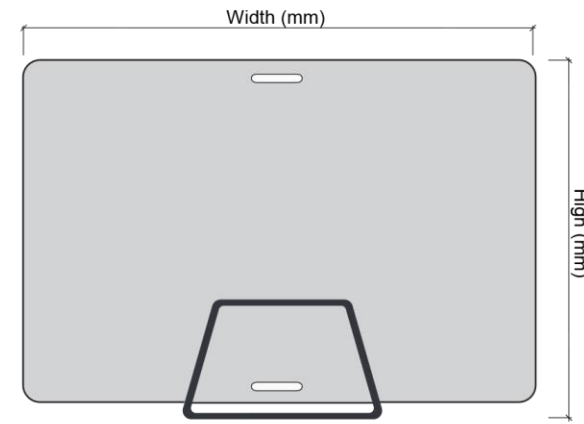

Front

Acrylic (12mm thk)

Width : 1500W (mm)
High : 1000H (mm)

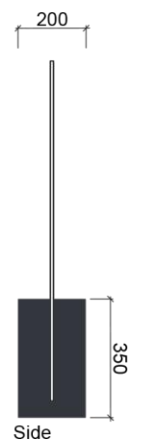

Side

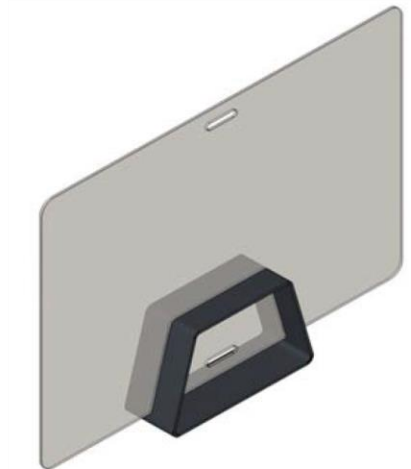
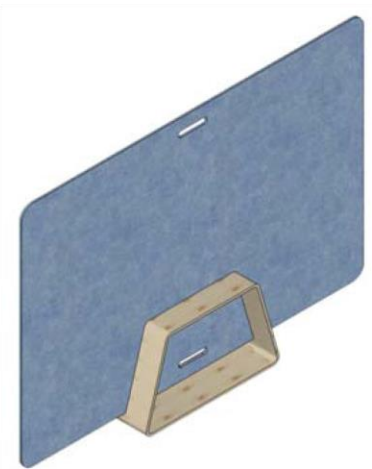

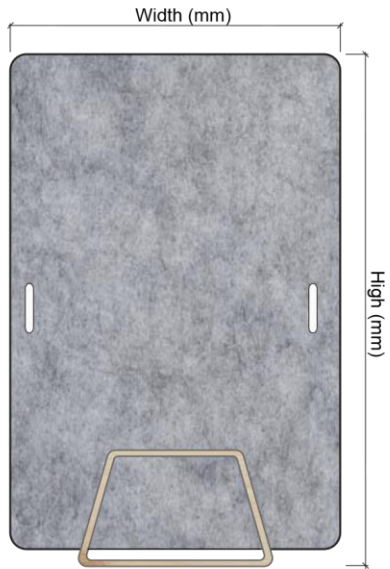

Front
Ekous (12mm thk)
Width : 1000W (mm)
High : 1500H (mm)

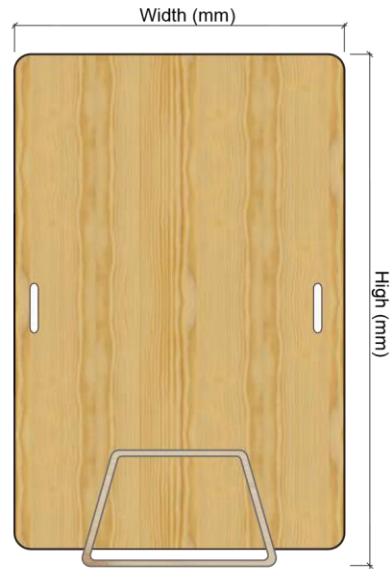

Front
MFC (12mm thk)
Width : 1000W (mm)
High : 1500H (mm)

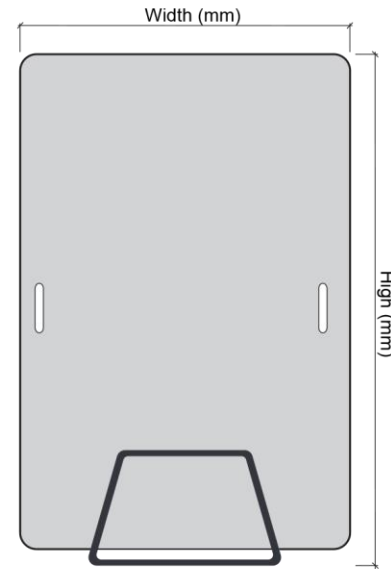

Front
Acrylic (12mm thk)
Width : 1000W (mm)
High : 1500H (mm)

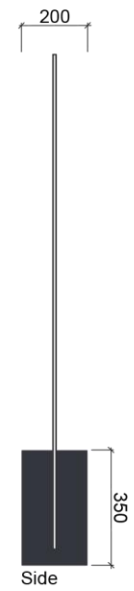

Side



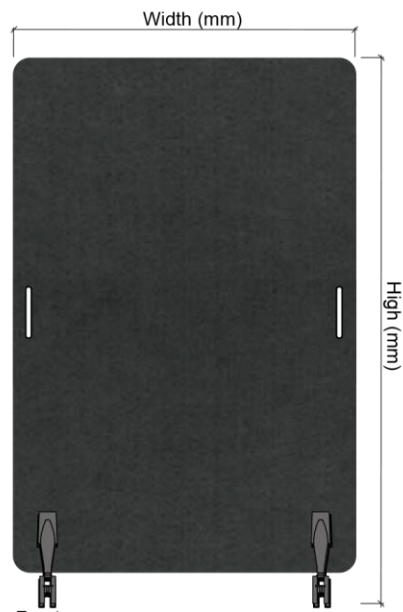

Front

Ekous (9mm thk)

Width : 1000W (mm)

High : 1500H (mm)

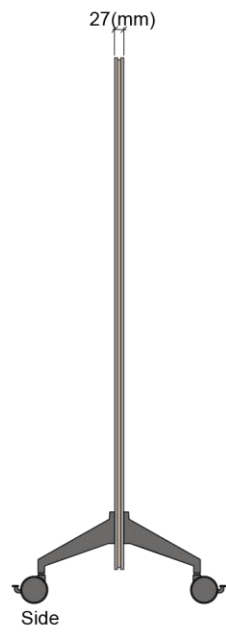

Side

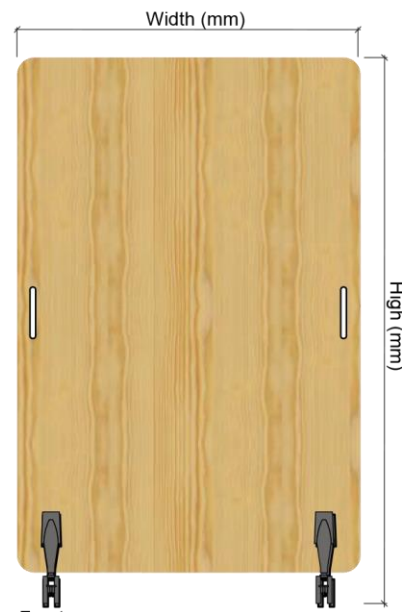

Front

MFC (18mm thk)

Width : 1000W (mm)

High : 1500H (mm)



Side

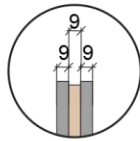

Sonata color swatches



SR15-Spectrum Red



BB21-Bright Blue



SY22-Smart Yellow



GG14-Green Grass



CH17-Charcoal



OPTIONAL MATERIALS

MFC color swatches



3C8-Alisia Walnut



3D4-Olive Ash



3E1-Prunus



374-Ivory Maple



303-Cherry

Acrylic sheet



6mm thk



9mm thk



12mm thk



TAZ CORPORATION SDN BHD

Main office

13-1 to 13-3, Block F1,
Jalan PJU 1/42, Dataran Prima,
47310, Petaling Jaya, Selangor
Malaysia

Ekous Sound Lab

19-5, Block D,
Jalan PJU 1/39, Dataran Prima,
47310, Petaling Jaya, Selangor
Malaysia

www.ekous.net